



2022/23

Form A

Pilot ID

Flight #

CIVA Advanced Programme1

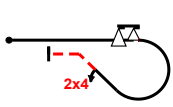
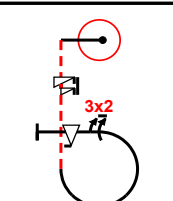
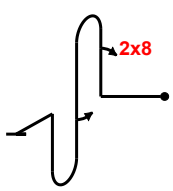
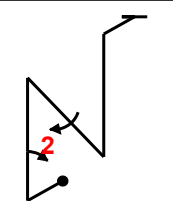
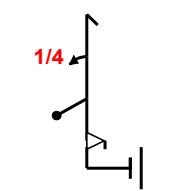
No	Symbol	Cat. No.	K	Total K	Grade	Pos	Remarks	Item	K	Grade
1		8.5.8.3 9.9.3.6 9.4.2.2	11 14 7	Fig A  32	.			Pos.	30	
								Harm.	0	
								Fig K	Total K	
2		8.6.4.3 9.11.1.6 9.2.3.6 9.9.3.4	13 3 12 11	Fig B  39	.			Fig K	Total K	
								174	204	
								<b>Penalties</b>		
3		8.8.2.1 9.8.1.1 9.1.5.2	19 7 4	Fig C  30	.			Too Low		
								Too High		
								Interruptions		
								Insertions		
								Trg Violation		
								Wing Rocks		
								Disqual Fig		
Other(note...)										
4		1.3.13.1 9.1.1.2 9.2.4.4	22 8 9	Fig D  39	.			<b>Final Freestyle</b>		
								Duration	Min	Sec
5		5.2.1.1 9.1.1.1 9.9.5.2	17 6 11	Fig E  34	.			<b>Judges Details</b>		
								Signature		
								Name		
Number										

\_\_\_\_\_  
 ..... Pilot  
 ..... A/C

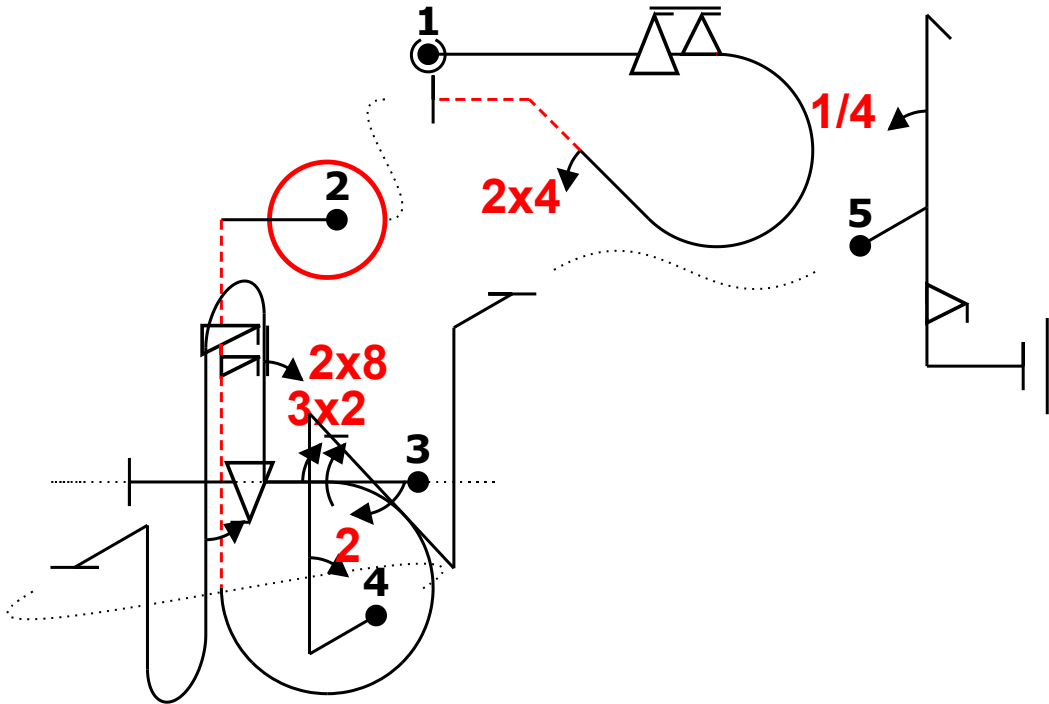
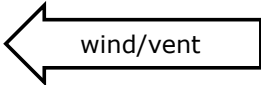

<b>Power</b>			
Fig	Aresti	K	
1 A	8.5.8.3 9.9.3.6 9.4.2.2	11 14 7	32
2 B	8.6.4.3 9.11.1.6 9.2.3.6 9.9.3.4	13 3 12 11	39
3 C	8.8.2.1 9.8.1.1 9.1.5.2	19 7 4	30
4 D	1.3.13.1 9.1.1.2 9.2.4.4	22 8 9	39
5 E	5.2.1.1 9.1.1.1 9.9.5.2	17 6 11	34
<b>Total K = 174</b> (max K = 320)			

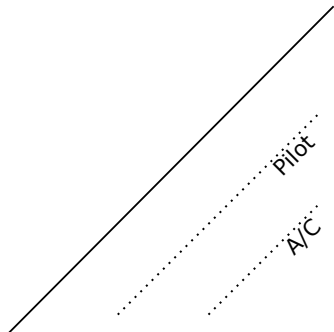



2022/23

Form C

Pilot ID

Flight #

CIVA Advanced Programme1

